

# Arc Trainer® Heart Rate Grip

Kit No. 620AK002 without drill bit  
620AK007 with drill bit

Installation Instructions

**NOTE:** This instruction sheet describes how to install the heart rate grips on the 620A and 629A Arc Trainers.

## Tools Required

- Flat head screwdriver
- Phillips screwdriver
- Rubber hammer
- Drill and 15/32" bit (Optional)
- Tape
- Wire cutters
- 7/32" Allen wrench
- Safety Glasses

1. Read and understand all instructions thoroughly before installing this kit.

2. Verify kit contents. See Figure 1.

- A. Top plastic sensor grip, (2), 610A-407
- B. Bottom plastic sensor grip, (2), 610A-408
- C. Heart rate cable, (1), AW-19870
- D. Self tapping screw #6 x 1.00, (4), [HT532517](#)
- E. 15/32" drill bit, (1), TE000008

**NOTE:** Drill bit comes in kit #620AK007 only.

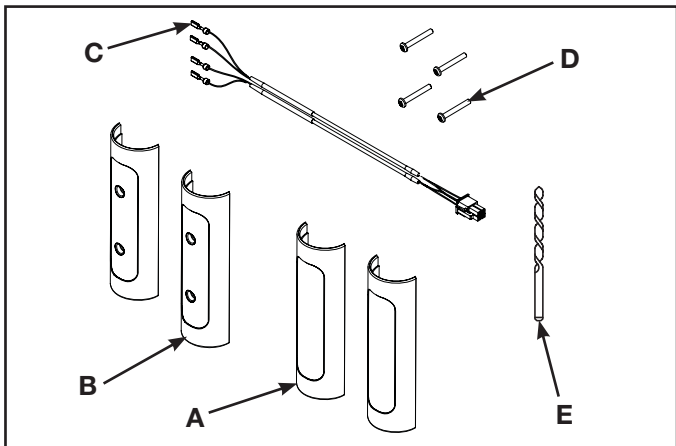

Figure 1

3. Identify the style of grips you have.

- A. Old style grips do not contain any screws that are visible.
- B. New style grips contain two screws that are visible on the finger side.

4. Remove old style grips and sensor.

A. With a flat head screwdriver, carefully pry off each metal sensor plate from grip and disconnect both heart rate wires. See Figure 2.

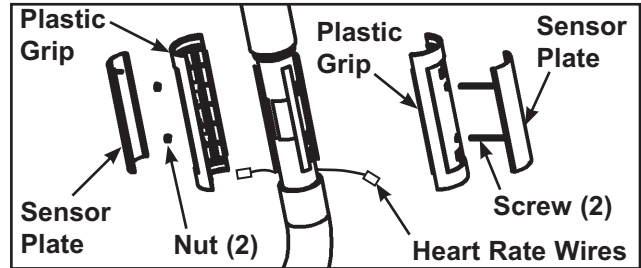

Figure 2

B. Using a Phillips screwdriver, remove the two screws and two nuts securing the grip in place. See Figure 2.

5. Remove new style grips.

A. Using a Phillips screwdriver, remove the two screws securing the grips in place. See Figure 3.

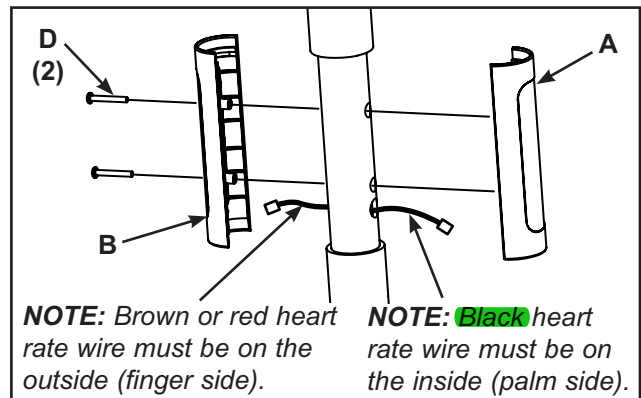

Figure 3

B. Disconnect the heart rate wire from each grip. See Figure 3.

6. Disconnect heart rate cables.

A. Using a 7/32" Allen wrench, remove the four BHSCS (Button Head Socket Cap Screw) and four washers securing the console assembly to the frame. See Figure 4.

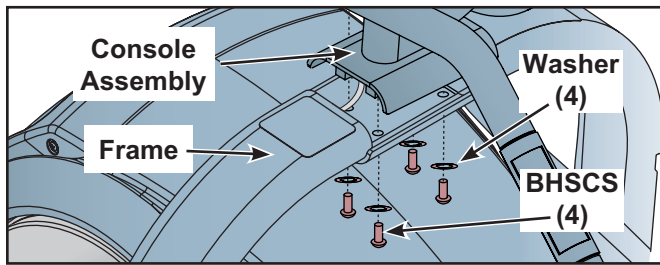

Figure 4

- B. Using a flat head screwdriver, pry off the plastic insert from the hand assembly. See Figure 5.

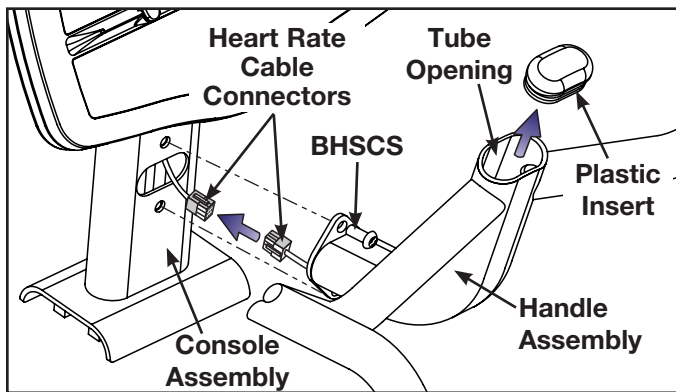

Figure 5

- C. Using a 7/32" Allen wrench, remove the two BHSCS securing the hand assembly to the console assembly. See Figure 5.
- D. Unplug the heart rate cable connectors. See Figure 5.
- E. Pull the hand assembly heart rate cable up through the tube opening. See Figure 5.

#### 7. Removing old cable and installing new cable.

**NOTE:** The cable on the clip side of the connector will be labeled left and needs to go to the left handle.

- A. Using a wire cutter, cut off the connector from the old cable.
- B. Using tape (not supplied with this kit), tape the new cable to the old cable ensuring a secure connection. **NOTE:** Verify the wire labeled left goes to the left handle.
- C. Pull the old cable through handle until end of the new cable is through the handle opening.

#### 8. Connect heart rate cables.

- A. Route the heart rate cable connector down through the tube exiting the bottom. See Figure 5.
- B. Plug the two heart rate cable connectors together. See Figure 5.
- C. Using a 7/32" Allen wrench, attach the two BHSCS removed in step 6C securing the hand assembly to the console assembly. See Figure 5.
- D. Using a 7/32" Allen wrench, attach the four BHSCS and four washers removed in step 6A securing the console assembly to the frame. See Figure 4.

- E. Reattach the plastic insert removed in step 6B. See Figure 5.

#### 9. Installing the grips and metal sensors.

- A. Verify that the holes in the handle are 15/32". If not, use a 15/32" drill bit to enlarge the holes.
- B. Remove tape securing the old cable and new cable.
- C. Slide the brown or red wire through the large (upper) outside or finger side hole. Slide the **black** wire through the inside or palm side hole. See Figure 3.
- D. Connect the **black** wire to the tab on the top plastic sensor grip (A). See Figure 3.
- E. Connect the brown or red wire to the tab on the bottom plastic sensor grip (B). See Figure 3.

**NOTE:** Make sure that the contacts do not touch and no wires are pinched while attaching grips.

- F. Using a Phillips screwdriver, attach the two screws (D) securing the grips A and B in place. See Figure 3. **NOTE:** Do not over tighten grips.
- G. Test unit for proper operation.

**NOTE:** If no heart rate reading is showing, verify that the **black** and the brown or red wire location is correct and that the cable labeled left is on the left side.